

New trends, room for  
"warm" ideas

Modern shapes and forms, plenty of space with flexible, functional solutions: the home is evolving. Aristons keen eye for new stylistic trends and changes in life styles is looking for new ideas to meet emerging needs. Like this built-in coffee center providing at a touch many wonderful warm sensations from a traditional espresso to a frothy cappuccino, you decide.  
**Increasing your design options; by creating additional space with new functionality and taste.**

Coffee has conquered  
new spaces

Coffee Centers

 **ARISTON**

ed. 02/06



 **ARISTON**

## At your finger tips!

A highly ergonomic design. Nothing could be more stylish or more practical than the menu buttons integrated right in the control panel. Let the coffee center prompt your every command with a light touch to the menu keypad as you create your coffee sensation.

# 1



## Easy access right in front of your eyes.

# 4

Ease of use also means easy access. Access to the coffee beans, water container as well as areas requiring periodic cleaning. Just press the control panel and it slowly drops open allowing you to make your necessary adjustments.



Providing you to use a wide array of cup sizes, from small espresso cups to travel mugs up to a height of 6"



## Making the most of space.

Whether you want to integrate the coffee center into your kitchen or into another spot in the home your counter space will not be sacrificed. It's shallow depth and sleek styling integrates into any cabinet design.

# 2



## Not your ordinary coffee maker.

Thanks to the 2 heating element systems you can create a latte or cappuccino simultaneously as the coffee is being brewed. This convenience attends to even the largest dinner party. Or make a hot tea as you brew that perfect espresso.

# 5



## Open to new possibilities

# 6

Coffee at a touch, new design options or just dare to be different. In any case, the coffee center provides unlimited choices for you, your friends and your home.



## Light or Strong.

The advantage of customized brewing to the cup makes it possible for you to preset the coffee strength to your preference. Easily increase or decrease to the liking of your family and guests with a turn of the dial.

# 3



Model	MCA 15 NA	MCA 15 P NA
Type of Product	Built-In Coffee Center - Non Plumbed	Built-In Coffee Center - Plumbed
Styling	Experience Line	Experience Line
Product Features		
Frothing System	•	•
Fully Automatic Grinding System	•	•
Coffee Flavor Temperature & Strength Control	•	•
Grinding Time / Fine Grinding Option	•	•
Pre-brewing option	•	•
Pre-grinding option	•	•
Steam Temperature option	•	•
Hot water feature	•	•
Drink Temperature Setting	•	•
Water Hardness Adjusting Option	•	•
Automatic Rinsing Option	•	•
Number of Heating Units	2	2
100% Front Accessible	•	•
Setting Stand-by Timer	•	•
Water Reservoir	•	•
Display and Functions		
Control Buttons	Touch Through Stainless Steel	Touch Through Stainless Steel
LED Display	•	•
20 Plus Programmed Functions Available	•	•
Number of Dispensers	2	2
Multiple Height Adjustment of Coffee Dispenser	80-105 mm; in the back 150mm / 3 1/8 - 4 1/8 inches; in the back 6 1/8 inches	80-105 mm; in the back 150mm / 3 1/8 - 4 1/8 inches; in the back 6 1/8 inches
Flexible Entertaining	•	•
Stainless Steel Drip Tray	•	•
7 Language Selections	English, French, Spanish, Italian, German, Portuguese, and Dutch	English, French, Spanish, Italian, German, Portuguese, and Dutch
Espresso, Cappuccino, Latte, Coffee, Tea, Hot Water	•	•
Product Characteristics		
Dimensions (WxHxD)		
Product only	540mm x 460mm x 302mm / 21.26" x 18.11" x 11.89"	540mm x 460mm x 302mm / 21.26" x 18.11" x 11.89"
Faceplate	595mm x 460mm x 20mm / 23.43" x 18.11" x 0.79"	595mm x 460mm x 20mm / 23.43" x 18.11" x 0.79"
Product with Packaging	700mm x 550mm x 400mm / 27.56" x 21.66" x 15.75"	700mm x 550mm x 400mm / 27.56" x 21.66" x 15.75"
Wall Cabinet Cutout Dimensions	540mm x 450mm x 320mm / 21.26" x 17.72" x 12.60"	540mm x 450mm x 320mm / 21.26" x 17.72" x 12.60"
Electrical		
Voltage / Frequency / Amperage / Wire	120 V / 60Hz / 15 Amp / 3-wire	120 V / 60Hz / 15 Amp / 3-wire
Power Chord Length	3 m / 9.84 ft	3 m / 9.84 ft
Grinding System	Ceramic Disc Grinding Gear, 150 Watt	Ceramic Disc Grinding Gear, 150 Watt
Water pump power	48 Watt	48 Watt
Coffee warming power	1300 Watt	1300 Watt
Steam Heating Power	1300 Watt	1300 Watt
Absorbed Power	100 Watt	100 Watt
Weight		
Product only	13.5 kg / 29.8 lbs	13.5 kg / 29.8 lbs
Product with Packaging	16.0 kg / 35.3 lbs	16.0 kg / 35.3 lbs
Capacity		
Water pump pressure bar / kPa	15 bar / 1500 kPa	15 bar / 1500 kPa
Bean Container Capacity	300 gr / 10 ounces	300 gr / 10 ounces
Grind Coffee per Cup	8 gr / 0.26 ounces	8 gr / 0.26 ounces
Waste unit Capacity	approx. 15 pieces	approx. 15 pieces
Water reservoir	2.0 l (with water filter 1.7 l) / 67.63 fl. Ounces	2.0 l (with water filter 1.7 l) / 67.63 fl. Ounces
Direct Plumb Access for Water	•	•
Accessories		
Water Filter - WF1000	•	•
Decalcification Liquid - DL1000	•	•

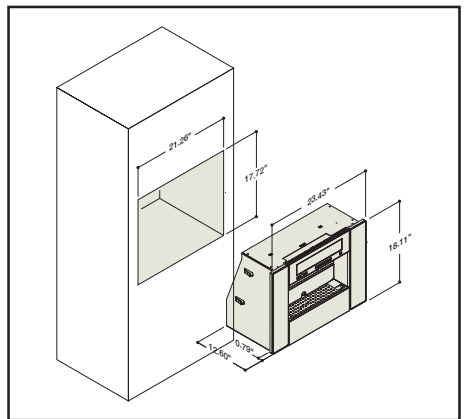

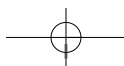

**Crease Care**

In each drying program the special final Crease Care option, periodically tumbles the clothes until you come back eliminating any chance of wrinkles. Post Crease Care can be combined with the delay dry option, eliminating any wrinkling of clothes prior to the start of the cycle.



**Air Fluff**

Air Fluff option is a 10 minute cycle for you dryer that helps refresh the clothes that have been in your closet for a long time: eliminating any bad smells.



**Less time spent ironing, more free time**

Ariston's new washing machines special **Easy Iron** option provides the ability to eliminate wrinkling caused when clothes are left in the drum. Just press the easy iron option button and the clothes will be held in water until you press the Easy Iron button again. This means no wrinkles. Now it will not only be a pleasure to do your laundry but ironing will be quicker and easier.



**As soft as silk**

Thanks to the Silk program, machine washing a silk garment as if it were a cotton item will become a completely normal action.



**No more pain, no more stains**

Even the most stubborn stains disappear without any pre-wash thanks to the special **Bleach** compartment which integrates the selected program increasing the additive's cleaning power. And above all there is no need to pre-wash by hand when combined with the **Soaking Option**.



**You choose when to wash**

The **Delay Timer** lets you program the wash start time for any time of the day even if you are not at home, up to 24 hours in advance. This includes the dryers which gives you a delay time of up to 12 hours. Now you can really react to your schedule.



**Detergent free too**

You will not find any trace of detergent which may ruin your garments or irritate sensitive skin. The special **Extra Rinse** option lets you add a further rinse level to the selected program in order to get rid of all traces of detergent.



**Your daily wash**

If you want fresh, clean laundry every day, the **Daily Wash** program lets you freshen up garments of different fabrics in no time at all - 30 minutes for a 7.5 pounds load washing in temperatures up to 120°F. Need it in a pinch?



**Detergent loss prevention**

100% detergent cleaning power is captured thanks to the pressure system which keeps the active soap in the washer and not down the drain. So it's nice to know your washing machine is not wasting a drop of detergent providing the maximum in cleaning efficiency.

**170° Sanitary Cycle**

Cleaning without additives is a nice option you can choose with Ariston. Its internal heating element boost the water temperature for sanitizing results.

**Controlled results**

Your washing machine is constantly monitored in order to ensure best washing results thanks to the **Sensor System** - a series of control systems. Your dryer is equipped with moisture sensor constantly monitoring the dryness level and your desire. Just set and forget and your clothes will come out at the dryness level you desire.



**Better than ever**

Improve the efficiency of your home with a washer that holds the lowest operating cost of any washer available; exceeding the requirements of **Energy Star** and still allowing you to handle big loads up to 15lbs.



Model	AW 149 NA	AW 129 NA	AW 125 NA	ASL 75 CXS NA	ASL 65 VYS NA	AS 65 VYS NA
Product Line	washing machine	washing machine	washing machine	condenser dryer	vented dryer	vented dryer
Color	platinum	platinum	platinum	platinum	platinum	platinum
<b>Performances</b>						
Energy test capacity	15 lbs / 7.0 kgs	15 lbs / 7.0 kgs	12 lbs / 5.5 kgs	15 lbs / 7.0 kgs	13 lbs / 6.0 kgs	13 lbs / 6.0 kgs
Maximum load	16 lbs / 7.5 kgs	16 lbs / 7.5 kgs	13 lbs / 6.0 kgs	16 lbs / 7.5 kgs	15 lbs / 6.5 kgs	15 lbs / 6.5 kgs
Approval	UL / cUL	UL / cUL	UL / cUL	UL / cUL	UL / cUL	UL / cUL
Alarm at end of cycle	•	•	•	•	•	•
Time to end	•	•	•	•	•	•
Variable spin speed	Up to 1400 rpm	Up to 1200 rpm	Up to 1200 rpm	•	•	•
<b>Primary Functions</b>						
Sanitary Wash	•	•	•	•	•	•
Cotton Wash	Heavy, Regular, Light	Heavy, Regular, Light	Heavy, Regular, Light	•	•	•
Permanent Press Wash	Heavy, Regular, Light	Heavy, Regular, Light	Heavy, Regular, Light	•	•	•
Delicates Wash	Delicates, Silk, Wool	Delicates, Silk, Wool	Delicates, Silk, Wool	•	•	•
Sensor drying	•	•	•	Cotton / Permanent Press	Cotton / Permanent Press	•
Automatic drying	•	•	•	•	•	Heavy load, Light load
Timed drying	•	•	•	up to 160 min	up to 120 min	up to 120 min
Fabric care	Daily Wash	Daily Wash	Daily Wash	•	Delicates / Wool	•
<b>Additional Options</b>						
Delay Timer	up to 24 hrs	•	•	up to 12 hrs	up to 18 hrs	•
Easy Iron	•	•	•	•	•	•
Others	Super Wash Pre Wash Soaking	Super Wash Pre Wash / Extra Rinse Soaking	Super Wash Pre Wash Extra Rinse	Air Fluff Pre & Post Creasecare High- Low Heat	Air Fluff Pre & Post Creasecare High- Low Heat	Air Fluff High- Low Heat
<b>Dimensions</b>						
Product only (HxWxD)	850mm x 595mm x 580mm 33.47" x 23.43" x 22.84"	850mm x 595mm x 580mm 33.47" x 23.43" x 22.84"	850mm x 595mm x 535mm 33.47" x 23.43" x 21.07"	850mm x 595mm x 584mm 33.47" x 23.43" x 23.00"	850mm x 550mm x 595mm 33.47" x 21.66" x 23.43"	850mm x 595mm x 550mm 33.47" x 23.43" x 21.66"
Product with packaging (HxWxD)	910mm x 635mm x 615mm 35.83" x 25.00" x 24.22"	910mm x 635mm x 615mm 35.83" x 25.00" x 24.22"	910mm x 635mm x 595mm 35.83" x 25.00" x 23.43"	910mm x 635mm x 638mm 35.04" x 25.12" x 26.38"	910mm x 610mm x 638mm 35.04" x 24.02" x 25.12"	910mm x 638mm x 610mm 35.04" x 25.12" x 24.02"
Door opening	13"	13"	13"	17"	13"	13"
Venting hole	•	•	•	•	bottom left rear	bottom left rear
<b>Weight</b>						
Product only	158.7 lbs / 72.0 kg	158.7 lbs / 72.0 kg	145.5 lbs / 66.0 kg	70.6 lbs / 32.0 kg	67.3 lbs / 30.5 kg	67.3 lbs / 30.5 kg
Product with packaging	162.1 lbs / 73.5 kg	162.1 lbs / 73.5 kg	149.7 lbs / 67.9 kg	81.6 lbs / 37.0 kg	70.6 lbs / 32.0 kg	70.6 lbs / 32.0 kg
<b>Technical Data</b>						
Voltage / Frequency	120 volts / 60 hz	120 volts / 60 hz	120 volts / 60 hz	208-240 volts / 60 hz	208-240 volts / 60 hz	208-240 volts / 60 hz
Amperage / Wire	11 Amps / 3 prong plug	11 Amps / 3 prong plug	11 Amps / 3 prong plug	30 Amps / 4 prong plug	30 Amps / 4 prong plug	30 Amps / 4 prong plug
Cable length	6 ft. / 1.8 mts	6 ft. / 1.8 mts	6 ft. / 1.8 mts	6 ft. / 1.8 mts	6 ft. / 1.8 mts	6 ft. / 1.8 mts
Drum	Stainless Steel	Stainless Steel	Stainless Steel	Stainless Steel	Stainless Steel	Stainless Steel
Antifoam protection	•	•	•	•	•	•
Overflow / Flood protection	•	•	•	•	•	•
Maximum absorbed power	•	•	•	2100 - 2750 W	2000 - 2600 W	2000 - 2600 W
Adjustable feet	•	•	•	•	•	•
<b>Accessories</b>						
Instruction Manual	English, Spanish, French included	English, Spanish, French included	English, Spanish, French included	English, Spanish, French included	English, Spanish, French included	English, Spanish, French included
Warranty card	•	•	•	•	•	•
Included accessories	connection hoses	connection hoses	connection hoses	stacking kit / adaptor for ventilation kit	stacking kit / adaptor for ventilation kit	stacking kit / adaptor for ventilation kit
Pedestal with drawer (APE 2000 S)	sold separately	sold separately	sold separately	sold separately	sold separately	sold separately
Pedestal without drawer (APE 1000 S)	sold separately	sold separately	sold separately	sold separately	sold separately	sold separately

(\*): Certain limitation apply, see manufacturers limited warranty for details / UL and cUL listed. Ariston reserves the right to bring changes to the products without notice.

For more information contact

**WESTLAND SALES**  
SALES MARKETING DISTRIBUTION

15650 SE 102ND AVE. (PO BOX 427)  
CLACKAMAS, OR 97015-0427

**1-800-356-0766**  
(503) 655-2563

or visit [www.westlandsales.com](http://www.westlandsales.com)

Ed. 07/07



Laundry

**ARISTON**

**AW 129 NA**



1200 rpm spin speed  
 Electronic / Smart Controls  
 Multiple spin speed adjustments  
 Multiple Temperature settings  
 Energy Star certified  
 11 wash settings  
 Super Silent Triphase Motor  
 Woolmark Platinum Care  
 Super Wash option  
 Easy Iron option  
 Pre-wash option  
 Extra Rinse option  
 Daily Wash  
 Silk program  
 Sanitary Cycle (internal heating element)  
 Soaking option  
 16 lbs maximum load capacity  
 15 lbs Energy test washing capacity  
 Stainless Steel Drum  
 Dimensions (HxWxD): 33.5"x23.4"x22.8"

Stainless Steel Look / Platinum Color

**ASL 75 CXS NA**



Condenser - Electronic Controls  
 Bidirectional Rotation  
 180° (reversible) full metal door  
 Removable lint filter  
 Stacking Kit included  
 End noise signal  
 Sensor Controls  
 Timed Dry  
 Easy Iron Option  
 Air Fluff Option  
 Delay Timer (up to 12 hs)  
 Pre and Post Creasecare  
 16 lbs maximum load capacity  
 Stainless Steel Tub / Drum  
 Dimensions (HxWxD): 33.5"x23.4"x23.0"

Stainless Steel Look / Platinum Color

**AW 125 NA**



1200 rpm spin speed  
 Electronic / Smart Controls  
 Multiple spin speed adjustments  
 Multiple Temperature settings  
 Energy Star certified  
 11 wash settings  
 Super Silent Triphase Motor  
 Woolmark Platinum Care  
 Super Wash option  
 Easy Iron option  
 Pre-wash option  
 Extra Rinse option  
 Daily Wash  
 Silk program  
 Stain Removal / Bleach program  
 13 lbs maximum load capacity  
 12 lbs Energy test washing capacity  
 Stainless Steel Drum / Tub  
 Dimensions (HxWxD): 33.5"x23.4"x21.1"

Stainless Steel Look / Platinum Color

**AS 65 VXS NA**



Vented - Electromechanical Controls  
 Bidirectional Rotation  
 Bull-eye see-through door  
 Removable lint filter  
 Stacking Kit included  
 Sensor Controls  
 Timed Dry  
 Easy Iron Option  
 Air Fluff Option  
 15 lbs maximum load capacity  
 Stainless Steel Tub / Drum  
 Dimensions (HxWxD): 33.5"x23.4"x21.7"

Stainless Steel Look / Platinum Color

**AW 149 NA**



1400 rpm spin speed  
 Electronic Display / Smart Controls  
 Multiple spin speed adjustments  
 Multiple Temperature settings  
 Energy Star certified  
 11 wash settings  
 Super Silent Triphase Motor  
 Woolmark Platinum Care  
 Super Wash option  
 Easy Iron option  
 Pre-wash option  
 Delay Timer (up to 24 hs)  
 Daily Wash  
 Silk program  
 Sanitary Cycle (internal heating element)  
 Soaking option  
 16 lbs maximum load capacity  
 15 lbs Energy test washing capacity  
 Stainless Steel Drum  
 Dimensions (HxWxD): 33.5"x23.4"x22.8"

Stainless Steel Look / Platinum Color

**ASL 65 VXS NA**



Vented - Electronic Controls  
 Bidirectional Rotation  
 Bull-eye see-through door  
 Removable lint filter  
 Stacking Kit included  
 End noise signal  
 Sensor Controls  
 Timed Dry  
 Easy Iron Option  
 Air Fluff Option  
 Delay Timer (up to 18 hs)  
 Pre and Post Creasecare  
 Wool Program  
 15 lbs maximum load capacity  
 Stainless Steel Tub / Drum  
 Dimensions (HxWxD): 33.5"x23.4"x21.7"

Stainless Steel Look / Platinum Color

For planning purposes only, for details see care & use manual.

For planning purposes only, for details see care & use manual.

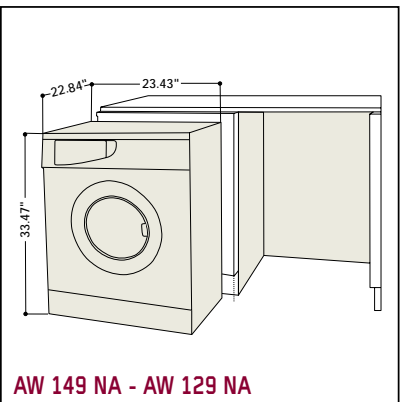

**AW 149 NA - AW 129 NA**

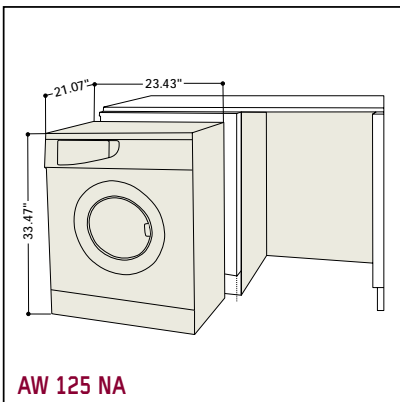

**AW 125 NA**

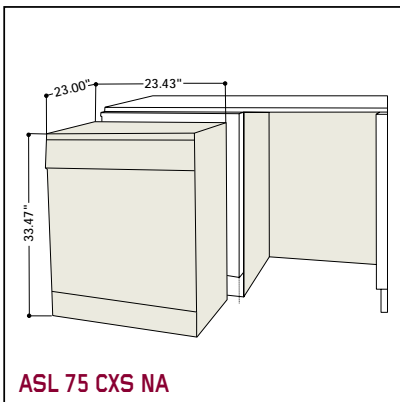

**ASL 75 CXS NA**

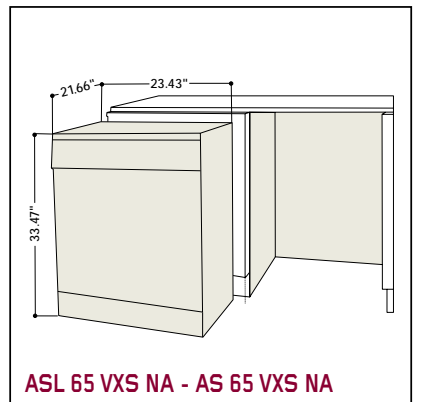

**ASL 65 VXS NA - AS 65 VXS NA**